

INCLINATION REFERS TO COMPLETE TOP RIM

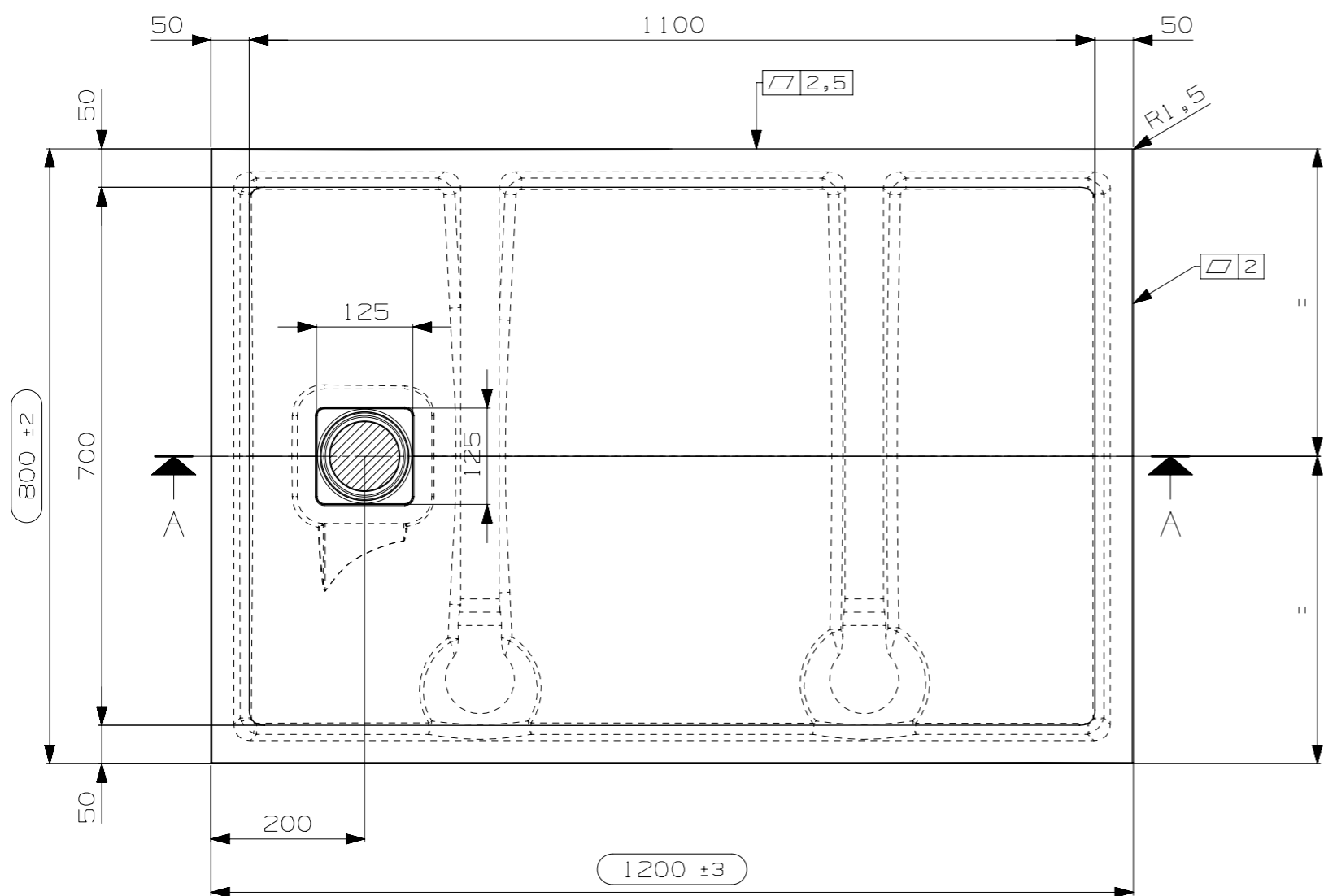

N° DATA/Date	FIRMA/drawn by	DESCRIZIONE REVISIONE/Revision description
1		

NOTE/Notes		N° STAMPO/Mould Number
.....		M07566A
.....		PROG. 14-296
VEDI SCHEDE ALLEGATE		PESO NETTO/Weight
.....		Kg. 34,5
.....		PS 2000
.....		DATA REV.0/Date Rev.0
.....		04/06/2018
CLIENTE/Client	MODELLO/Model	EMESSO/Drawn by
NICOS	LISCIO	FABRIZIO D.
DENOMINAZIONE/Product Name		VERIFICATO/Checked by
PIATTO DOCCIA 120x80		A. MANIAGO
TUTTE LE QUOTE E TOLLERANZE INDICATE IN QUESTO DISEGNO SI RIFERISCONO A MISURAZIONI EFFETTUATE AD UNA TEMPERATURA DEL MANUFATTO DI 20°C +/-5°C.		PROIEZIONE/Projection
All the dimensions and the tolerances of this drawing are referred to mesurements taken with a temperature of the piece of 20°C +/-5°C.		

TOLERANCE NOT SPECIFIED	>1-4	>4-30	>30-120	>120-400	>400-1000	>1000-2000
	±0,5	±1	±1,5	±2,5	±4	±6

MATERIALE : MINERALSOLID  
 FINITURA : LISCIO