

SECTION H-H
SCALE 35:200

CALIBRARE

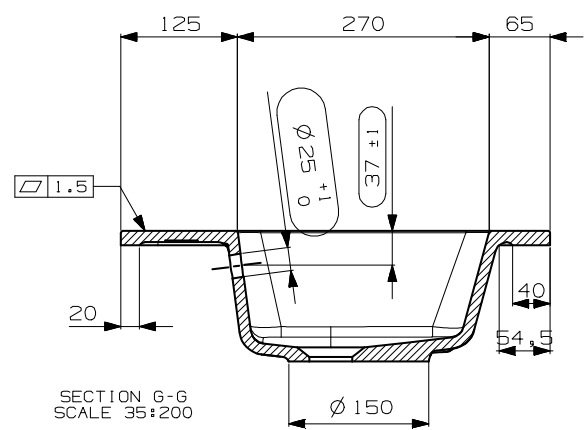

SECTION G-G
SCALE 35:200

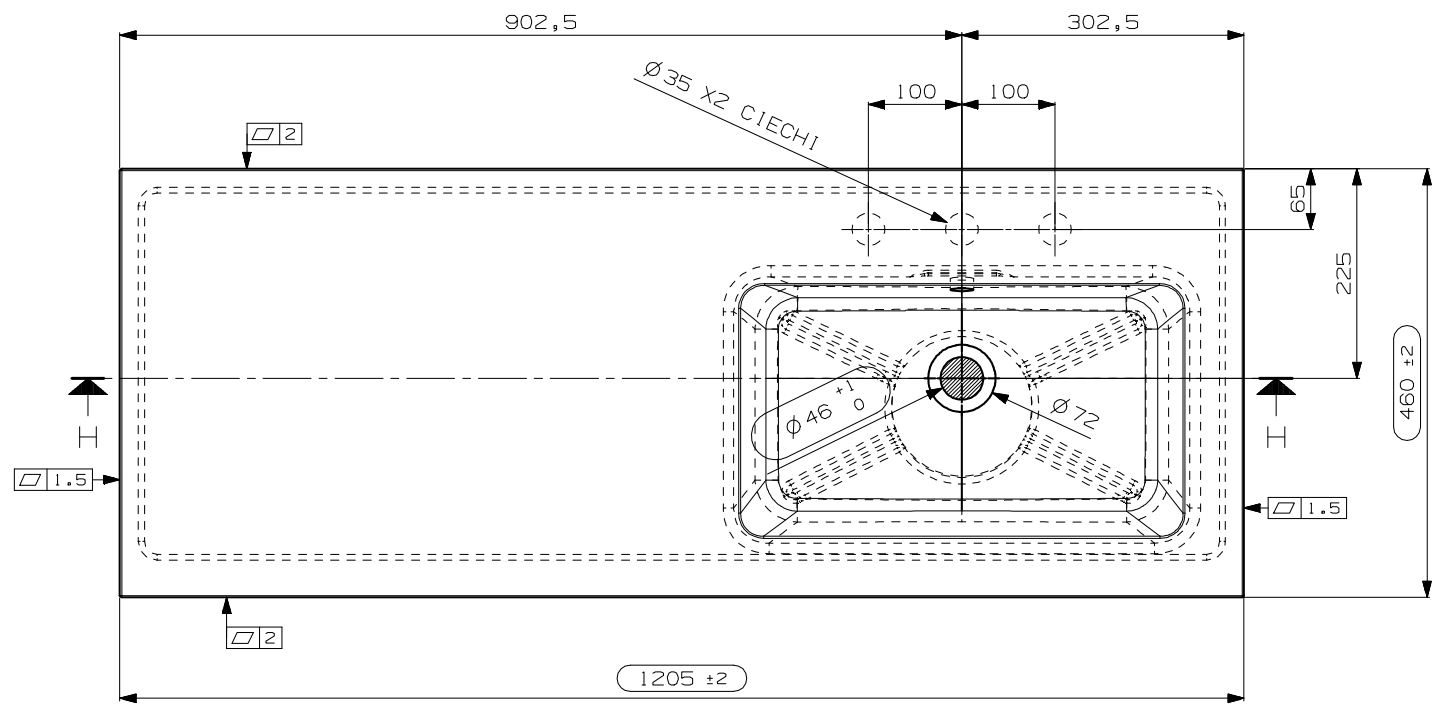

N° DATA/Date	FIRMA/drawn by	DESCRIZIONE REVISIONE/Revision description
1		

NOTE/Notes	N° STAMPO/Mould Number
.....	MOB209A
.....	Prog. 18-146
.....	PESO NETTO/Weight
.....	Kg. 16
.....	DATA REV.0/Date Rev.0
.....	05/06/2020
.....	CLIENTE/Client
.....	NICOS INT.
.....	MODELLO/Model
.....	MAX
.....	EMESSO/Drawn by
.....	S. SANTAROSSA
.....	DENOMINAZIONE/Product Name
.....	LAVABO DX 120x46 VASCA 48 S/F - C/TP
.....	VERIFICATO/Checked by
.....	A. MANIAGO

QUESTO DISEGNO E' DI PROPRIETA' DI NICOS INTERNATIONAL S.p.A.; SECONDO I TERMINI DI LEGGE E' VIETATA LA RIPRODUZIONE O LA DIVULGAZIONE DEL CONTENUTO DI QUESTO DISEGNO SENZA AUTORIZZAZIONE SCRITTA. This drawing is property of Nicos International S.p.A.; it is illegal to reproduce or divulge this drawing without written permission.

TUTTE LE QUOTE E TOLLERANZE INDICATE IN QUESTO DISEGNO SI RIFERISCONO A MISURAZIONI EFFETTUATE AD UNA TEMPERATURA DEL MANUFATTO DI 20°C +/- 5°C. All the dimensions and the tolerances of this drawing are referred to measurements taken with a temperature of the piece of 20°C +/- 5°C.

